

TECHNICAL DATA SHEET FOR Gas Salamander 900mm CS9



CS9

- 900mm wide
- Stainless steel finish
- Dual high performance infrared burners
- Removable easy-clean bottom tray
- Independently controlled sides
- Flame failure protection on each burner
- Wall mounting bracket supplied
- Optional: Branding plate

Overall Construction

Stainless steel exterior
Aluminised steel interior
Stainless steel crumb tray
Chrome plated rack and rack supports
Two individually controlled infra-red burners
Suitable for bench or wall mounting

Controls

Large easy use control knobs
Dual controls with variable high to low burner setting
Flame failure on each burner

Cleaning and Servicing

Removable grill rack system, rack supports and crumb tray
Easy clean stainless steel exterior
Access to all parts from front of unit

TECHNICAL DATA SHEET FOR Gas Salamander 900mm CS9

Burners

2 x 4.4kW, 15,000Btu/hr

Gas power (gross)

8.8kW, 30,000Btu/hr

Gas connection

R $\frac{1}{2}$ (BSP) female
130mm from right side,
25mm from rear

Dimensions

Width 900mm
Height 450mm
Depth 389mm
(422 with wall mounting bracket)

Cooking area

Rack size
610mm x 310mm, 1890cm 2

Packing data

0.32m 3
Width 940mm
Depth 520mm
Height 640mm
42kg nett weight
69kg packed weight

Gas types

Available in Natural gas and LP gas,
please specify when ordering

All units are supplied with a gas
conversion kit

Options at extra cost

Branding Plate
610mm x 310mm, 1890cm 2

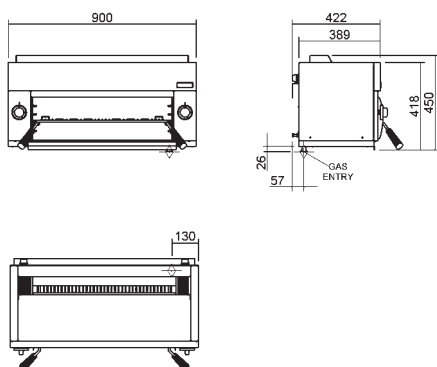

CS9



www.blue-seal.co.uk

United Kingdom
Blue Seal Limited

Unit 67
Gravelly Business Park
Gravelly
Birmingham B24 8TQ
England
Ph 0121-327 5575
Fax 0121-327 9711
sales@blue-seal.co.uk
www.blue-seal.co.uk

Australia
Moffat Pty Limited

740 Springvale Road
Mulgrave
Victoria 3170
Australia
Ph 03-9518 3888
Fax 03-9518 3833
vsales@moffat.com.au
www.moffat.com.au

New Zealand
Moffat Limited

16 Osborne Street
PO Box 10-001
Christchurch 8011
Ph 03-389 1007
Fax 03-389 1276
sales@moffat.co.nz
www.moffat.co.nz



Designed and manufactured by



ISO9001
All Cobra products are designed and
manufactured by Moffat using the
internationally recognised ISO9001
quality management system, covering
design, manufacture and final
inspection, ensuring consistent high
quality at all times.



In line with policy to continually develop
and improve its products, Moffat Limited
reserves the right to change
specifications and design without notice.