



RoHS
CE



Data sheet

Depth	670 mm
Height	838 mm
Width	598 mm
Inner depth	482 mm
Inner height	652 mm
Inner width	477 mm
Noise level	40 dB(A)
KW/24h	1.47 Kw
Capacity	200 L
Consumption	125 W
Net Weight	40 Kg
Temperature	0°C ~ +8°C

Technical features

- 200 Lt. Refrigerated upright (CLASS B)
- S/S external cabinet, thermoformed internally
- Roll-bond evaporator system with fan assisted cooling
- Automatic compressor cycle defrost
- Foaming Agent Cyclopentane (45mm per side)
- Digital Thermostat
- Removable Gasket
- Reversible door
- Lock and main switch fitted as standard
- Adjustable shelves: 2 Pcs
- Stainless steel external handle
- N.2 Adjustable feet + N.2 Rollers at the back

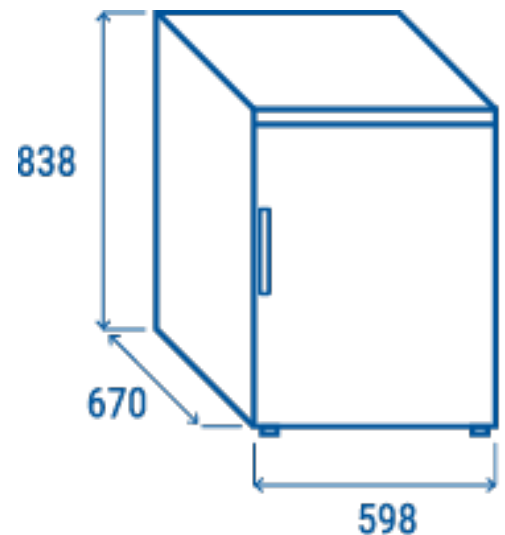

Main switch, digital thermostat and door lock fitted as standard



External cylindric handle in stainless steel (Steel color for X Version)



Inner assistance fan