



RoHS
CE



Data sheet

Depth	700 mm
Height	883 mm
Width	900 mm
Inner depth	586 mm
Inner height	502 mm
Inner width	810 mm
Noise level	53.9 dB(A)
KW/24h	2.42 Kw
Capacity	232L
Consumption	142.4 W
Net Weight	86 Kg
Temperature	+0° ~ +8°C

Technical features

- GN1/1 Refrigerated saladette (OPEN TOP)
- Stainless Steel exterior and interior
- Static cooling
- Automatic compressor cycle defrost
- Foaming Agent Cyclopentane (45mm per side)
- Digital Thermostat
- Sliding engine room for a manageable after sales servicing
- Plastic thermal-braker as chamber body frame
- Easy removable condenser filter
- Separated plastic water tray
- Front panel tilted holes for better air circulation
- Adjustable shelves GN1/1: 2 Pcs
- Self closing door (New inner embossed design for a better sealing)
- Removable Gasket
- Engine room lock fitted as standard
- N.2 Adjustable feet in the front + N.4 fix rollers
- Holder spacer for GN pans with "hook" design (included)

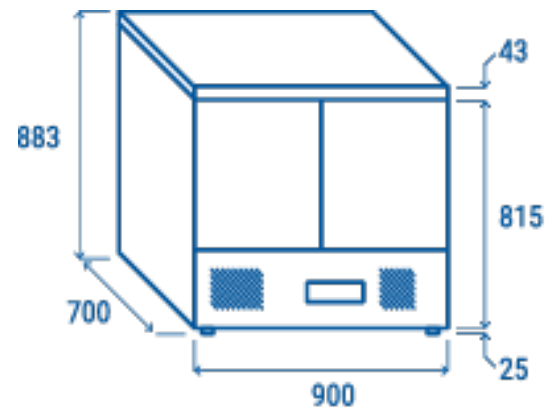

Curved edge for easy cleaning



Engine room lock fitted as standard



Anti-condensation thermal-braker on door frame



Inner embossed door design for a better sealing

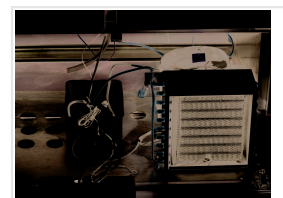

Sliding engine easy to pull out for manageable after sales servicing



Inner assistance fan



Top view of the unit



Door design