

MT | AND EVERYTHING FALLS INTO PLACE.

The versatile. The powerful. The custom-made flight-type or rack conveyor dishwashers. For large-scale dishwashing. Economical and reliable.



One machine for perfect cleanliness and hygiene. Perfectly coordinated accessories. Specially-developed chemicals. Advice. Training services. Service. All that and more from Winterhalter.



FLEXIBLE SYSTEM

The MT Series of flight or rack conveyor, are modular in design and come with a variety of configurations and setup options. The flexible system is considered, highly engineered and proven in practice.

CUSTOM SOLUTION

Every industrial kitchen is different: the space available on-site, the items being washed and the washing times, the washing process and the individual requirements. That's why a conveyor dishwasher from Winterhalter is always the result of detailed planning: our specialists configure the perfect MT for you.

ECONOMICAL AND EFFICIENT

With integrated economy function: by enhancing and optimising the rinse zone, the water consumption of the MT Series has been reduced to a minimum. The resultant benefit: The consumption of energy and chemicals falls even further.



NO EXPERIMENTS.

Peak times. Guests en masse. Large-scale dishwashing. An industrial kitchen plays by its own rules. It's a job for the MT Series: the high-performance conveyor dishwashers do their job effortlessly. No matter what happens. Everything falls into place. They are easy to use and economical. Modular design, individually configurable. Made just for you. Machines you can rely on, and guaranteed safety.

MTF | FLIGHT-TYPE MACHINE

For uniform dishes at pre-defined times. In refectories, hospitals, large canteens and nursing facilities.



MTR | RACK CONVEYOR DISHWASHER

For a wide range of wash items distributed throughout the day. In hotels, restaurants, service stations, smaller canteens and nursing facilities.



USER-FRIENDLY

180-degree rotating doors. Open and close effortlessly with just one finger. Touch screen with language-neutral pictograms. For intuitive programme selection. Typical MT: well-thought-out details make operation as simple, safe and convenient as possible.

MAXIMUM CLEANLINESS AND HYGIENE

Designed for the highest hygiene standards: the MT Series meets all provisions and regulations of the DIN standard. If you have special requirements, you can wash at even higher temperatures with the optional HighTemp function. So you are ready for all eventualities.



A detailed overview of the MT Series is available on our website at:

>> www.winterhalter.com/mtr

>> www.winterhalter.com/mtf



HYGIENE CONCEPT

Easy-to-clean doors. Smooth insides and back wall. Deep-drawn tanks without corners or edges. Plus an exhaust air system with grease filter. Heat exchanger cleaning system. And an automatic self-cleaning programme with ceiling cleaning jets. The MT is consistent and is designed with lots of small details for maximum hygiene. Ensuring the best-possible safety for you.

EXHAUST AIR HEAT RECOVERY

Intelligent use of input energy: The MT Series is also available with the exhaust air heat recovery option, Energy. It uses the energy from warm exhaust air to pre-heat the cold inlet water. This considerably reduces the energy consumption and lowers operating costs. The optional ClimatePlus* heat pump is even more efficient: It extracts even more moisture and heat from the machine exhaust air. The intelligent dual cleaning system for the heat exchanger proves the efficiency of the exhaust air heat recovery and guarantees hygiene, even in hard-to-reach areas of the machine.

DOUBLE-SKINNED DESIGN

The MT represents high-quality design and workmanship: the machine is completely double-skinned and insulated. The full effect of this concept however can only be witnessed in combination with the closed base plate. Here the cost-reducing effect of the heat insulation is even greater and the machine noise is considerably reduced.

RACK-CONTROLLED ZONE ACTIVATION

Another innovative feature of the MT Series: The individual zones for pre-wash, main wash and rinse are activated only when they are actually needed – i.e. when there are dishes in the respective zone. This conserves resources and lowers your operating costs. Because water, power, detergent and rinse aid are used efficiently and economically.

PROVEN FILTRATION

It is used in all warewashers and keeps the detergent solution clean: the proven Winterhalter filtration system. With a comprehensive filter in each pre-wash and main wash tank, a pump inlet filter and 3 Mediamats in the rinse zone. Using just centrifugal force, the Mediamats filter out tiny particles such as coffee grounds from the lye-mixed water. Simple, but effective.

* Fluorinated greenhouse gases contained in a hermetically sealed device; refrigerant R134a, 2.19 kg, 3.1 tonnes of CO₂ equivalent; greenhouse gas potential 1430.





»Our rooms and layouts are rigidly designed, the existing work processes stay as they are. What we need is a warewasher that is perfectly adapted to our requirements – not the other way round. MT gives us exactly that.«

Birgit Kaiser, CATERING OPERATIONS MANAGER,
EBZ COMPANY CANTEEN | RAVENSBURG

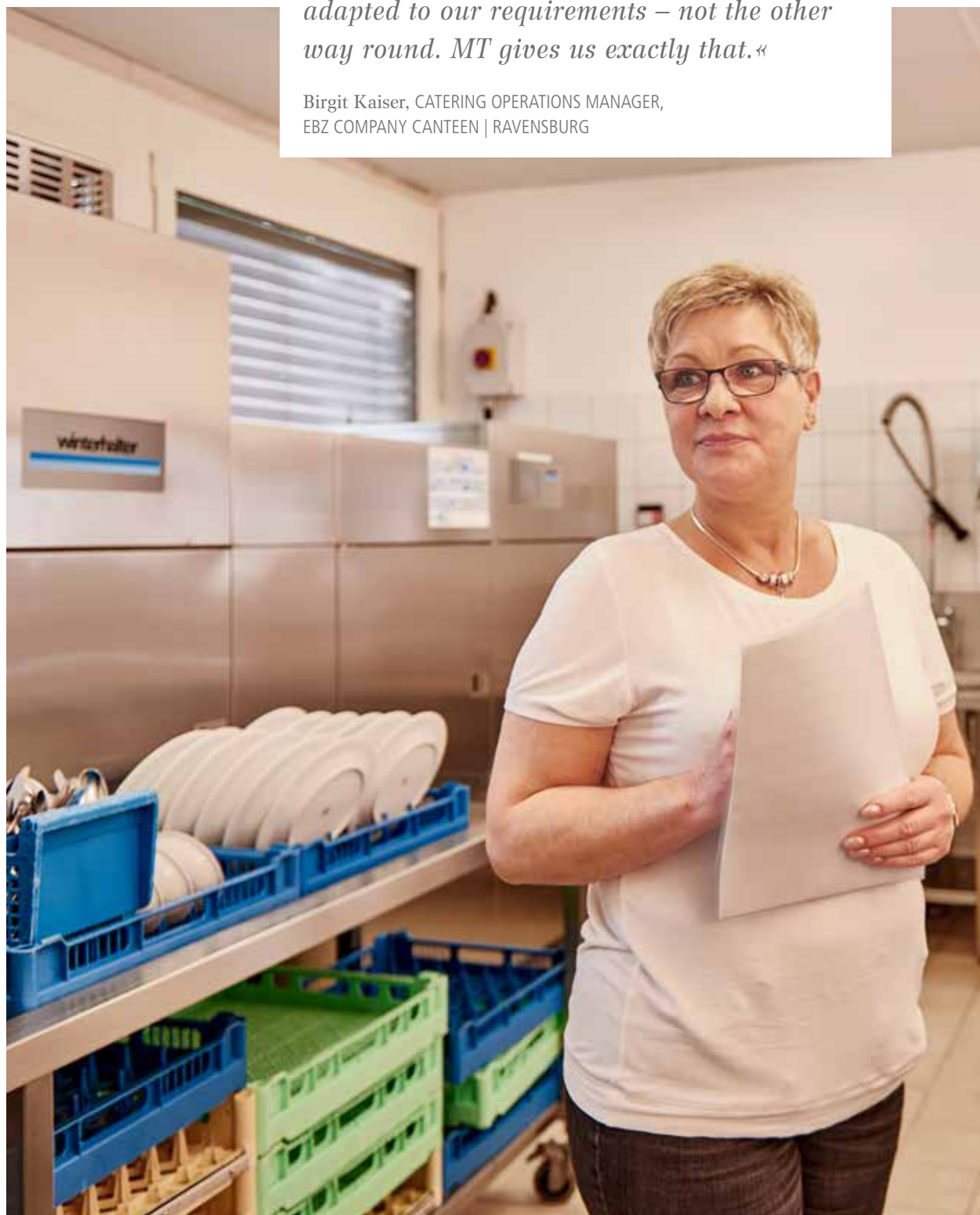

Cleanliness and hygiene. Every single one of our products plays its part. Together they create the perfect wash result. Welcome to the complete Winterhalter system!

CONVEYOR BELTS AND RACKS

They are custom-made for glasses, dishes or cutlery. With their functional design they adapt precisely to the respective wash items, protecting them and preventing damage. They ensure ideal water and air circulation and fast drying. And, naturally, they simplify handling and transportation of the wash items.

Wash conveyor belts and wash racks have a decisive influence on the quality of the wash result and the sum of operating costs. We advise which conveyor belts and which racks best suit your requirements. Culminating in the best solution for you.



WASHING CHEMICALS

Even the best warewasher can only deliver first-class results if not impeded by the detergent and rinse aid. To put it another way: the washing quality rises and falls with the quality of the chemical products. For this reason they are an extremely important component within the overall Winterhalter system.

At our headquarters in Meckenbeuren we have established a research department with an in-house laboratory. Here we develop and test formulae for a premium range of detergents and hygiene products. These are precisely tailored to the different wash items and types of contaminants; they are economical and can be ideally combined with other products in the range. Thus they are mutually beneficial and deliver a brilliant overall wash result.



WATER TREATMENT

Deposits. Streaks. Spots. They are »little greetings from the kitchen« and the natural enemies of any restaurateur. Because they are a sign of poor washing quality. Because limescale impairs the effect of detergent and rinse aid, and damages the machine in the long-term. The problem is water quality – the solution is professional water treatment.

Winterhalter has developed the DuoMatik 3 softener especially for the large volume of items being washed in the MT Series: the external device requires no power supply and works mechanically to ensure consistently high-quality water – and it does this without a regeneration break thanks to two alternating ion exchange cartridges. If you have even higher water quality standards: the compact RoMatik 420 reverse osmosis device achieves almost 100 % desalination, even where large volumes of water are required. The result is gleaming wash results, with no need for subsequent polishing.



SUPPORT AND PLANNING

Winterhalter is the specialist in commercial warewashing systems. Our knowledge encompasses the widest range of kitchens in the world. We know which aspects are important when it comes to washing, and which must be observed. And: we enjoy passing this knowledge and experience on to our customers.

Industrial kitchen challenge. This is where the MT Series comes into play. Here the situation is particularly complex: flight-type or rack conveyor – which is the best version? Free-standing or wall-mounted positioning? Corner or linear installation? What advantages would a heat pump offer? And how much is the current state subsidy? We help you answer every single question. In order to make the right choices in this investment.

Your partner, Winterhalter. Our team of advisers and planners analyse your individual on-site situation the layout, the room arrangement, the processes. We plan your estimated requirements and calculate the necessary equipment. We help you organise your washing operation, optimise the washing logistics, and provide instruction and training sessions for your employees. In short: when it comes to washing up, we're always there for you. From the start. And we help you to establish a professional and efficient washing process.

What can we do for you? Let's talk about it: Tel. +49 7542 402-5408 or www.winterhalter.com/contact



Karl Winterhalter



Jürgen Winterhalter



Ralph Winterhalter

»We are family people«

Down-to-earth. Forward-looking. With a focus on family. The culture and values of our family have shaped the Winterhalter company for three generations. Close to staff, customers and partners. Long-term thinking with a view to the generations to come. Taking personal responsibility – all typically Winterhalter. We are proud of our family company. And we are pleased to grow a little more every day.

THE FIRST WINTERHALTER



It all began in 1947: Karl Winterhalter established his own company in Friedrichshafen. He started by salvaging scrap metal from the war, which he used to manufacture household goods. Cooking pots and ovens, for example. A short time later he specialised, and in 1957 launched the GS 60 model: the first commercial warewasher from Winterhalter. That was the starting signal. Since then the company has always pursued a single goal: perfect wash results as part of an efficient washing process. With this holistic approach, Winterhalter has developed from a machine supplier to the full system provider of warewashing solutions it is today.

»Products, advice, service – three factors that intertwine seamlessly at Winterhalter. And that makes our customers feel safe in the knowledge that they have the right partner for any issue relating to the washing process.«

FROM WAREWASHER TO WAREWASHING SOLUTION

In days gone by, all we needed to do was deliver the new warewasher to our customer's kitchen on a hand truck. Now it's about the development of a new, individual warewashing solution, which is perfectly coordinated with the on-site situation and the special requirements and preferences of the customer. A solution of this type is based on clear analysis and planning. To achieve this, we visualise the room layout using state-of-the-art CAD software in 2D and 3D. For a bespoke and efficient washing process.



1.700

EMPLOYEES WORLDWIDE

High quality standards. Diligence. Curiosity and ambition. These are the typical attributes of a Winterhalter employee. And with them, we have grown from a small Swabian family company into a global player: with over 40 branches worldwide and distribution partners in over 70 countries. We are proud of what we have achieved. And we are proud of each and every employee who has done their bit. So we would just like to take this opportunity to officially say »Thank you!«



OUR ACADEMY OF WASHING SCIENCE

Almost 1,000 participants per year and 250 training days worldwide: as part of our training programmes we pass on our knowledge and experience in the discipline of »warewashing«. We provide training to our own personnel as well as to our retail and service partners. Our objective: every Winterhalter customer should receive informed advice and professional support in the specific situation. Whether it's an initial informative discussion, installing a warewasher, or service and maintenance appointments.

IN-HOUSE LABORATORY FOR IMPROVED CHEMICALS

As a specialist in warewashing, do we want to rely on the products of other manufacturers? The answer to this question was an immediate and resounding »No!«. This was the moment when our in-house research laboratory was born: we have been developing our own formulas for original Winterhalter chemicals for many years now: from detergents and rinse aids to hygiene products.

Good to know

As a specialist in warewashing, at Winterhalter we set high standards for ourselves: we don't just want to meet our customers' current requirements. We want to support them proactively and gain their trust for the long term. Service plays an important role here: our comprehensive network guarantees fast and professional support on site. Worldwide.

We and our service partners are there when you need us. On that you can always rely with Winterhalter.



What opportunities does new technology offer? How is our society and the world of work changing? Which trends and developments will shape commercial warewashing in the future? We find all of these questions extremely exciting. And that's why we are already working on developments that will affect us and our customers tomorrow, and the day after that. You can take a look at the solutions that we have developed in our NEXT LEVEL SOLUTIONS. Current examples include CONNECTED WASH and PAY PER WASH.

>> www.connected-wash.com >> www.pay-per-wash.com

»See you again soon«

Customers often own a Winterhalter warewasher for 15 or 20 years. So our customers only have to worry about disposing of their old equipment once every few decades. What's more, we take care of this ourselves. We design our machines as modular systems, so they are easy to dismantle if ever the need arises. We reduce the range of materials, use standardised construction materials and label plastic parts for easy recycling. Winterhalter warewashers have a particularly high recycling ratio thanks to these and many other measures.



MADE IN GERMANY AND SWITZERLAND

As ever, it is not simply an indication of origin, but a seal of quality: products made in Germany and Switzerland are recognised worldwide for their premium quality and total reliability. For engineering skill, ingenuity and precision. Winterhalter is the perfect testament to this: in Meckenbeuren, Emdingen and Rüthi, we develop and produce solutions for first-class cleanliness and hygiene. This is our promise for every single warewasher that leaves our factory.

GENERAL TECHNICAL DATA: MT SERIES

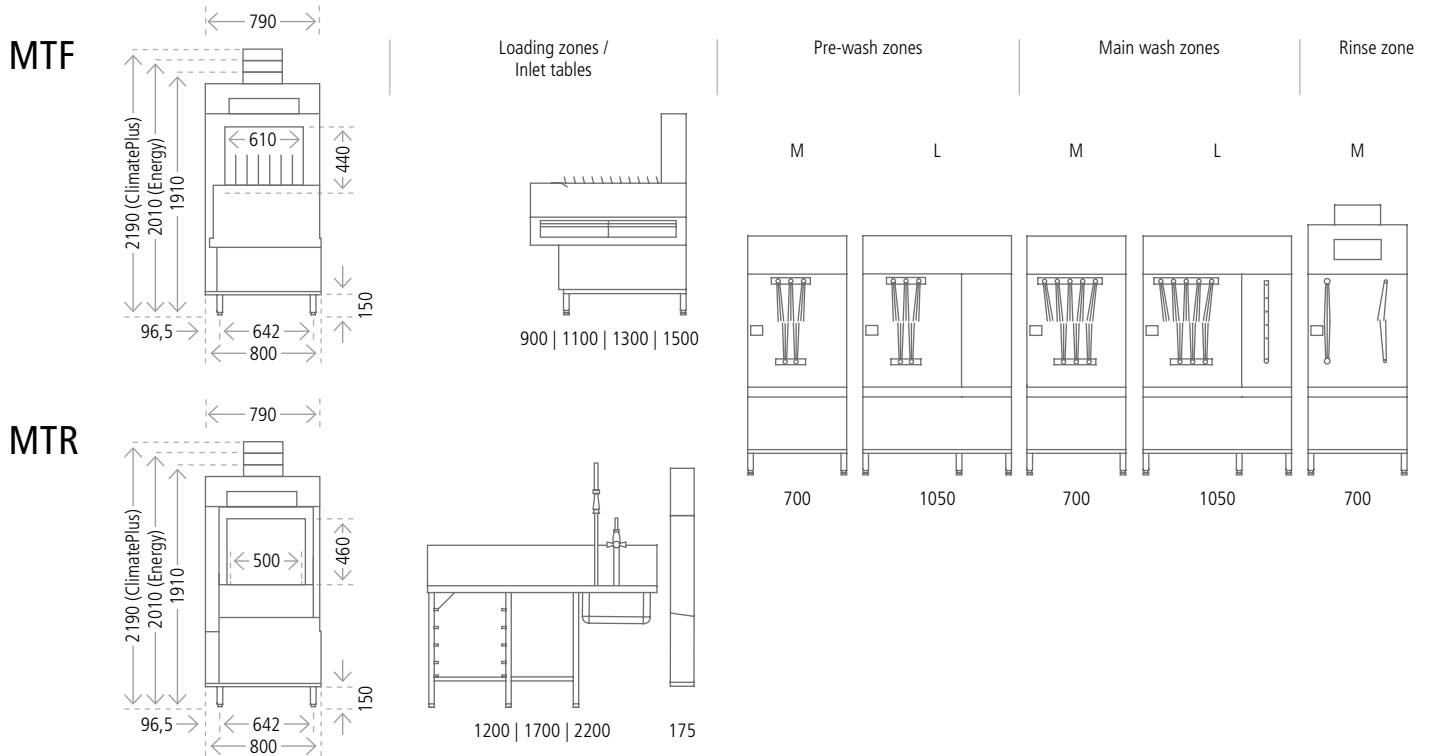

MTF Standard

Model		MTF 3-2800 MMM	MTF 3-3300 LMM	MTF 3-3300 MLM
Theoretical machine performance (65 mm conveyor belt)	Plates / h			
– Intensive programme		1200	1400	1400
– Standard programme		1800	2100	2100
– Rapid programme		2800	3300	3300
Machine length (without blowing-out, drying, loading and unloading zone)	mm	2100	2450	2450
Total water tank capacity	l	240	240	240
Rinse water volume with dual rinse (standard)	l / h	170	170	170
Rinse water volume with triple rinse (optional)	l / h	240	240	240

MTR Standard

Model		MTR 2-120 MM	MTR 2-155 SMM	MTR 2-155 LM
Theoretical machine performance	Racks / h			
– Intensive programme		50	65	65
– Standard programme		75	100	100
– Rapid programme		120	155	155
Machine length (without splash box, blowing-out and drying zone and table system)	mm	1400	1750	1750
Total water tank capacity	l	155	155	155
Rinse water volume with dual rinse (standard)	l / h	160	160	160
Rinse water volume with triple rinse (optional)	l / h	220	220	220

Blowing-out zones

Drying zones

Unloading zones /
outlet roller tables

Corner drying zones (MTR only)

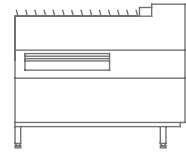
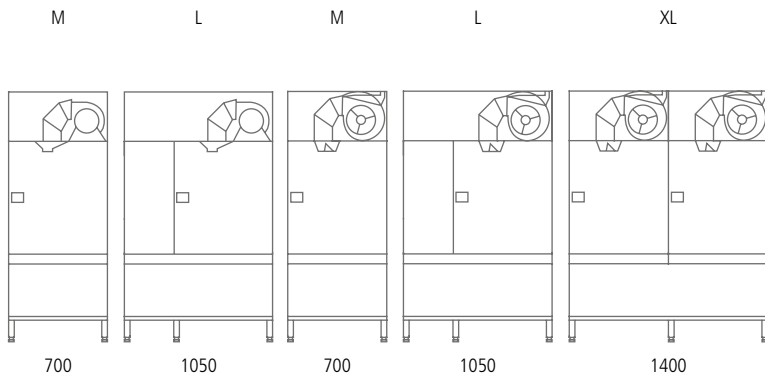

900 | 1200 | 1500 | 1800

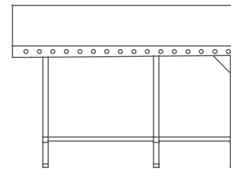

1200 | 1700 | 2200

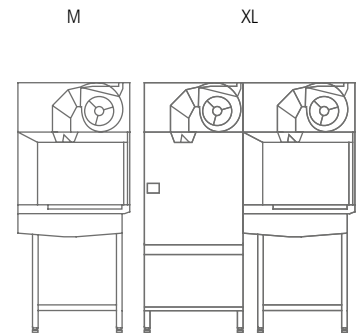

795

1495

MTF 3-3700 LLM	MTF 4-4100 MLMM	MTF 4-4800 LLMM	MTF 4-5400 LLLM	MTF 5-6600 LLLL
1600	1700	2100	2300	2800
2400	2600	3100	3500	4200
3700	4100	4800	5400	6600
2800	3150	3500	3850	4900
240	325	325	325	410
180	180	180	200	220
260	270	270	280	310
MTR 3-185 MMM	MTR 3-215 LMM	MTR 3-215 MLM	MTR 3-250 LLM	MTR 4-250 MMMM
80	90	90	105	105
120	135	135	160	160
185	215	215	250	250
2100	2450	2450	2800	2800
240	240	240	240	325
160	160	160	160	160
220	220	220	240	240



»In this brochure, we have presented our MT Series: its product features, application options and what sets it apart. However we were not able to provide you with the strongest argument of all here: the positive experiences of our satisfied customers. Just ask next time you see a MT anywhere. There is no better aid to making your decision.«

Jürgen und Ralph Winterhalter



01/19 30001967 Subject to technical alterations.